



MAGNETEK
MATERIAL HANDLING

200S Brakes

Technical Specifications



Part Number: 452039

April 2019

©Copyright 2019 Magnetek Material Handling

P.O. Box 13615
Milwaukee, WI 53213
Toll-Free Phone: 800-288.8178
Toll-Free Fax: 800-298-3503

N49 W13650 Campbell Drive
Menomonee Falls, WI 53051
Phone: 262-783-3500
Fax: 262-783-3510

Canada Facility:
4090B Sladeview Crescent
Mississauga, Ontario
L5L 5Y5 Canada
Toll-Free Phone: 800-792-7253
Fax: 905-828-5707

© 2019 MAGNETEK

All rights reserved. This notice applies to all copyrighted materials included with this product, including, but not limited to, this manual and software embodied within the product. This manual is intended for the sole use of the person(s) to whom it was provided, and any unauthorized distribution of the manual or dispersal of its contents is strictly forbidden. This manual may not be reproduced in whole or in part by any means whatsoever without the expressed written permission of MAGNETEK.

Table of Contents

1 Introduction	4
2 Mondel 200S Brakes	5
Applications	5
Standard Features	5
Optional Features	5
3 SA Brakes	6
Standard Features	6
Optional Features	7
Shunt Brakes	7
AC Rectifier Brakes	7
Series Brakes	7
Model Number of MSA Brakes	8
MSA Brake Specifications	10
4 ST and STE Brakes	11
Standard Features	11
Optional Features	12
EMG ELDRO® Hy-Thrust Actuator	12
Model Number of ST Brakes	14
MST Brake Specifications.....	16
AST Brake Specifications	17
IST Brake Specifications.....	18

INTRODUCTION

Magnetek's heavy-duty, cost-effective Mondel Shoe Brakes are designed for a wide variety of industrial, mining, and crane applications and environments. Minimal moving parts provide an extremely reliable range of brakes that are easy to install, adjust, and maintain.



MONDEL 200S BRAKES

The 200S Brake Series has a compact size with low shaft height, making it easy to retrofit into existing installations where space is tight. 200S brakes are made from fabricated steel and cast steel components. Cast iron is not used for any of the brake parts. The main pivot points are linked by corrosion- and wear-resistant stainless steel pins. The friction linings are made of environmentally safe, non-asbestos, REACH compliant material that provides a constant coefficient of friction and extended service life, which is improved even more when used with a Magnetek-supplied brake wheel. All hardware is painted, plated, or otherwise treated to prevent corrosion. Brake arms and shoes are standardized and interchangeable between different brake types of the same wheel diameter.

Applications

- Overhead Cranes
- Conveyors
- Hoists
- Bridges
- Movable Bridges
- Fans
- Winches
- Turntables
- Overhead Doors
- Lock Gates
- Strip Processing Equipment
- Ship Loaders
- Ore Bridges
- Machine Tools
- Other types of machinery requiring reliable stopping and holding

Standard Features

- Spring-applied and electrically released AC thruster or DC coil
- Compression springs (“torque springs”) develop force to apply braking torque
- Easy to install, adjust, and maintain
- Fast response times - standard AC thruster units with 2,000 cycles per hour
- Compliance to AIST/NEMA/DIN
- Electric actuators are CSA approved
- Designed for dusty and moist locations - sealed and gasketed actuators
- Anti-drag feature prevents shoes from dragging on wheel when brake releases
- Hitch pins used to retain pivot pins for ease of removal and quick maintenance

Optional Features

- Limit switches
- Manual hand-release mechanisms
- Stainless steel hardware corrosion protection
- Nitride corrosion protection
- Floor and wall mounting
- Explosion-proof AC thruster
- Special colors upon request
- Custom features, drop-in competitor replacements available upon request

SA BRAKES

The SA type brake is a spring-applied, electrically released DC shoe brake utilizing a short stroke magnet designed to produce a quick-acting brake with a low armature impact. The electromagnet (coil) is wound from Class "F" insulated copper wire. The coil is encapsulated into the steel magnet case with high-temperature thermo-setting epoxy that assists in the transfer of heat from the coil to the magnet case and seals the coil from dirt, moisture, oil, and other contaminants.



Standard Features

- Braking torque continuously adjustable to approximately 50% of the maximum torque
- Easy adjustments are provided for torque spring pressure, magnet air gap, and shoe clearance
- A weather-proof (Type 3R) terminal box is provided on all shunt brakes
- Air gap shield to prevent dirt from falling between the armature and the magnet
- Air gap indicator to clearly display minimum and maximum allowable armature air gap
- Easy replacement of coil subassembly via one pin connection
- Shunt-wound coils for 12VDC to 550VDC input
- Series-wound coils for 4 Amp to 300 Amp rated input

Optional Features

- Built-in rectifier or separately located rectifier
- Forcing method to improve brake reaction times, operating temperature, and coil life
- Non-latching hand-release mechanism, left side or right side of brake
- Limit switches indicating brake set, brake release, hand release action, or combinations thereof

Shunt Brakes

The power circuit of a shunt brake is usually independent from the power circuit of the motor. Standard shunt brakes are rated for continuous (8-hour) duty cycle and designed for Class “F” temperature rise at a maximum 104°F (40°C) ambient. At full torque, maximum air gap, and normal operating temperatures, the brakes are designed to release at 80% of full line voltage.

AC Rectifier Brakes

The reaction times for shunt brakes to switch between set and released states can be improved by implementing the “voltage forcing method.” With the voltage forcing method, a standard coil is “forced” by the application of 2 to 3 times the normal voltage for approximately a half second, and then reduced to a percentage of normal voltage while the brake remains released. The initial voltage boost releases the brake quicker, and the reduced holding voltage sets the brake quicker. The benefits of this include a cooler coil during operation and an extended life of the coil itself.

Other rectifiers allow SA brakes to be utilized with an AC power supply when a suitable DC supply is not available. Single-phase rectifiers can be mounted inside the brake terminal box or AC/DC controllers can be provided. Standard units are available for 230VAC, 460VAC, and 575VAC, single phase, 60Hz supplies.

Series Brakes

The power circuit of a series brake is wired in series with its DC motor. Series brakes are available with coils designed for 1/2 hour and 1-hour duty to correspond with the relevant motor horsepower ratings and currents. The brakes will release at 40% full-load motor current and remain released down to 10% full load motor current. Series brakes are best selected when motor, make, type, frame number, HP, RPM, voltage, Full Load Current, and duty cycle rating have been specified to the factory.

Other details:

Limit switch codes in the model number are described as indicating: brake set (M1), brake release (M2), and hand-release action (M3). An M1 limit switch can be re-wired to an M2 limit switch, and vice versa. The end user must configure the limit switch wiring during brake installation to indicate the desired response. The same limit switch is assembled to the brake and is triggered during service in the same way, regardless of the wiring. For this reason, the code (M1/2) is used in the model number, while M1 and M2 codes are not used in the model number.

When ordering brakes, please specify:

1. Desired torque for the brake to be factory set
2. Right side or left side of brake for nameplate to be installed at the factory
3. Right side or left side of brake for hand release to be installed at the factory, if applicable
 - When used with limit switch M1/2, hand release and limit switch must be on opposing sides
4. Right side or left side of brake for limit switch to be installed at the factory, if applicable
 - Limit switch M3 will be installed on same side as the hand release
 - Limit switch M12 configuration will use one limit switch on both right and left side of brake
 - Limit switch M12 configuration with hand release is not a standard design, consult factory
 - Limit switch M123 configuration is not a standard design, consult factory
5. Factory default method is to place nameplate, hand release, or limit switch on right side of brake if alternate placement is not specified

MSA Brake Specifications

ØBRAKE	DIMENSIONS																CONTINUOUSLY ADJUSTABLE TORQUE							
	A	B	C	D	E	F	G	H	J	K	L	M	N	P	Q	ØR	BOLT	S	2B	2C	MIN	MAX: SERIES-30min.	MAX: CONTINUOUS SHUNT & SERIES-30min.	MAX: FORCING RECTIFIER
4"	3.38	3.00	1.50	3.75	7.31	9.80	13.55	6.80	6.56	2.00	2.22	3.63	2.76	3.81	2.00	Ø0.38	5/16	0.38	6.00	3.00	11	15	18	22
6"	4.75	4.00	1.50	5.06	9.75	12.61	17.67	10.07	9.68	2.06	3.05	4.38	5.31	5.38	3.00	Ø0.44	3/8	0.50	8.00	3.00	35	40	50	67
8"	6.00	5.50	2.00	6.94	11.42	14.07	21.01	12.95	12.68	2.63	3.55	4.55	5.88	7.24	4.00	Ø0.44	3/8	0.50	11.00	4.00	70	100	140	140
10"	7.00	6.00	2.50	8.25	12.88	15.51	23.76	14.76	14.48	3.25	4.05	5.43	6.25	8.65	4.00	Ø0.56	1/2	0.50	12.00	5.00	190	200	240	290
12"	8.75	7.00	3.00	9.56	15.44	19.32	28.88	19.11	18.49	3.63	4.30	6.69	7.38	10.45	5.00	Ø0.56	1/2	0.63	14.00	6.00	280	335	425	510
13"	8.75	7.00	3.00	10.06	15.94	19.82	29.88	19.11	18.49	3.63	4.30	6.69	7.38	10.95	5.50	Ø0.56	1/2	0.63	14.00	6.00	300	365	460	550
15"	10.50	9.00	3.50	11.88	19.81	24.13	36.01	23.25	22.51	4.38	5.75	8.44	9.06	12.97	6.00	Ø0.69	5/8	0.63	18.00	7.00	560	610	750	960
16"	10.50	9.00	3.50	12.38	20.31	24.63	37.01	23.25	22.51	4.38	5.75	8.44	9.06	13.47	6.50	Ø0.69	5/8	0.63	18.00	7.00	600	650	800	1000

* all dimensions are inches

* All Torques are lb-ft

* Brake is shown with nameplate facing in right hand orientation

* M, N Dimension M or N, whichever is greater, is the minimum clearance required to remove all pins as shown

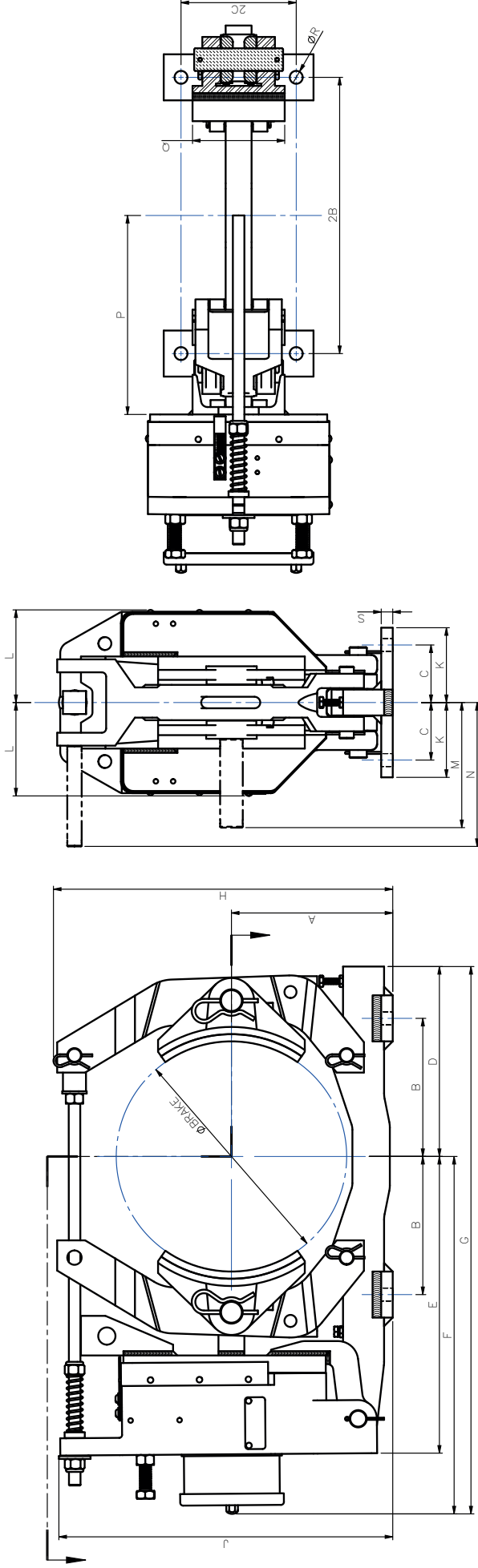

ST AND STE BRAKES

The ST and STE type brake is a spring applied, electrically released, 3-phase AC shoe brake, released by the completely sealed, continuously rated, EMG ELDRO® Hy-Thrust actuator.

This versatile brake can be applied to a wide range of applications and environmental conditions, where smooth, responsive stopping and holding is required. The hydraulic fluid in the thruster produces a naturally cushioned braking action and produces significantly fewer mechanical oscillations as compared to DC Armature or the AC Solenoid type brakes. The latter are notoriously expensive to maintain in terms of spare parts and downtime. The inherent cushioning effect makes the brake ideal for high duty cycles or jogging applications, virtually eliminating mechanical shock loading which increases component wear and failure.

Since the growth in popularity of AC controlled cranes, this brake has rapidly become the standard for all crane motions. It has the same high reliability that is normally associated with the DC Armature brakes but does not require a transformer/rectifier controller to supply DC power.

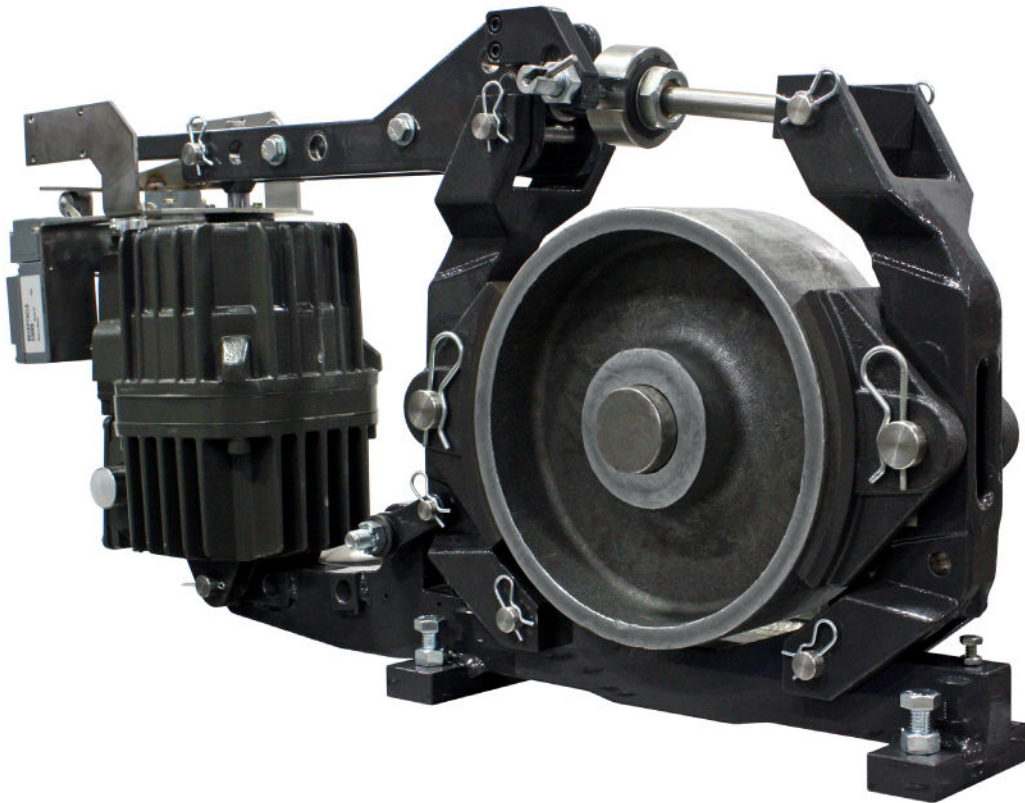

Standard Features

- High reliability, continuous-duty EMG ELDRO® thruster
- Bi-directional motor/pump unit in thruster, connect to supply in any phase sequence
- Supplies 110V through 660V - 3 Ph - 50 or 60Hz
- Ambient temperatures -31°F to 158°F (-35°C to 50°C)
- Compliance to AIST/AISE Technical Reports No. 11 and No. 6, AST type brakes
- Compliance to DIN 15435, IST type brakes
- Auto-Equalization: automatically equalizes running shoe clearance and maintains proper running, which provides balanced braking and equal brake lining wear

Optional Features

- Auto-Adjustment Mechanism: automatically compensates for brake shoe lining wear and maintains proper thruster reserve stroke; eliminates maintenance time required to manually adjust brake linkage for lining wear
- Adjustable external torque spring with calibrated indicator for torque adjustment (STE brake type)
- Built-in compression spring, four fixed linkage adjustments for torque adjustment (ST brake type)
- Configurable hand release: latching or non-latching style: quick change via one bolt, assembled in one of four handle positions: right side (R) or left side (L) of brake, near (1) or far (2) from motor axis (R1, R2, L1, L2)
- Limit switches indicating brake set, brake release, hand-release action, or any combination
- Externally adjustable, stepless time delays for brake set, brake release, or both
- Special thrusters for extreme temperatures and environments

ST and STE brakes are designed and stocked to comply with three industry standards.

- **MST brakes** – Magnetek original specification, compact, low shaft height design, complying with industry-leading Mondel brake installation requirements.
- **AST brakes** – Designed to comply with AIST/AISE Technical Reports No. 11 and No. 6 for standardization of shaft height, mounting footprint, and torque.
- **IST brakes** – Designed to comply with DIN 15435 specification for shaft height, mounting footprint, various dimensional requirements, and more.

EMG ELDRO® Hy-Thrust Actuator

EMG ELDRO® electro-hydraulic thrusters are proven, high-performance, reliable actuators that provide years of hassle-free service in harsh and extreme environments. Thrusters consist of a 3-phase motor with Class “F” insulation, centrifugal pump, and hydraulic piston. The motor is continuously rated. The terminal box is integral to the thruster, gasketed, IP65 rated, and has an M25 x 1.5 threaded inlet cable gland. The thruster must be connected to its power supply through a flexible cable or sealed flexible conduit due to thruster movement during brake service.

The thruster leaves the factory correctly filled with the fluid and seals for the specified ambient temperature range. The fluid will not deteriorate in service. If there are no obvious signs of leakage or inadequate performance, no additional fluid will be required and the oil does not require inspection.

The impeller runs free inside the cylinder, independent from the applied load. If the piston rod does not complete its stroke due to an excessive applied load, the motor is not subject to an overload condition and the pump is not damaged.

Full braking torque is achieved when the brake is set and the thruster piston is in the position of one-third of its total stroke. An Auto-Adjust pushrod will maintain this condition automatically. A Manual-Adjust pushrod must be adjusted periodically to maintain this condition, as the thickness of the friction linings naturally diminishes during service.

Thruster time delays are available. Time delays tweak the flow characteristics of the thruster working fluid via simple external adjustment screws. The brake setting (S) delay will increase the time required to achieve full brake torque by as much as 6 to 10 seconds, depending on the thruster. This enhances the setting action of the brake by reducing shock braking, and allows some kinetic energy to be dissipated in the system before brake torque develops, which is ideal for crane bridges, trolleys, conveyors, ship loaders, etc. This feature can also be used to provide a simple method of differentiating the service and emergency brakes on dual-drive applications. The brake releasing (H) delay will increase the time required to achieve complete brake shoe release by as much as 6 to 10 seconds, depending on the thruster. A typical application of delaying brake release is an inclined conveyor, where the feature allows time for the motor and fluid coupling to develop forward torque and prevent run-back.

The S and H delays are controlled and function independently. Thrusters are available with either or both delays. When time delays are not fitted, response times are approximately 0.4 to 0.8 seconds depending on the thruster. With time delays installed, the quickest response times will be about 50% greater than if they were not.

Magnetek is the only EMG-certified ELDRO® Electro-hydraulic Thruster Repair Facility in North America. Contact Magnetek customer service for all refurbishment and spare parts needs on ELDRO® Electro-hydraulic Thrusters.



ed23/5



ed/30/5



ed80/6



Model Number of ST Brakes

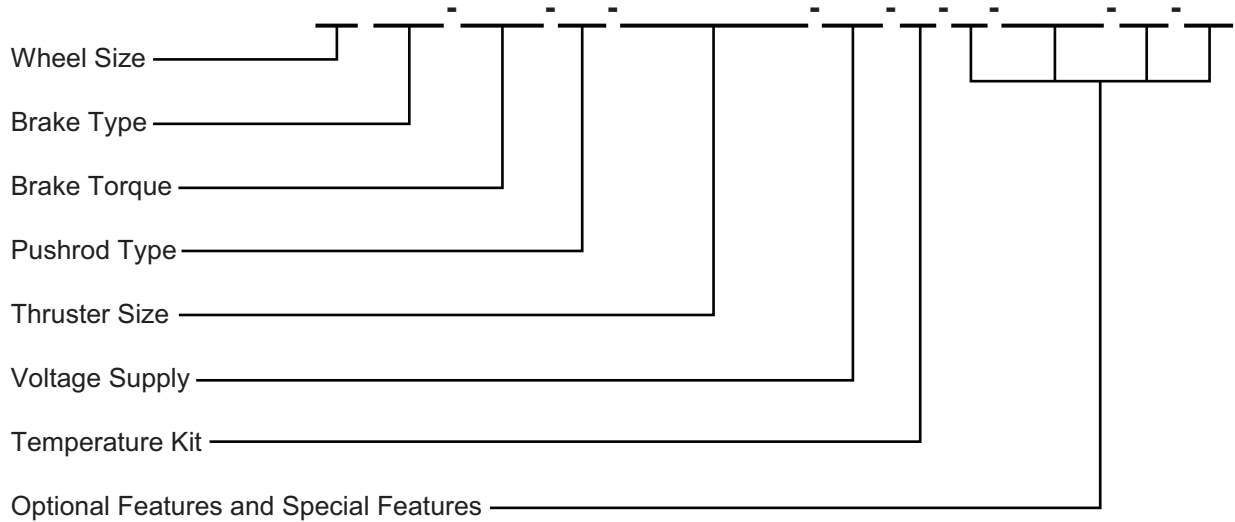

Brake Wheel Size: Standard Sizes: 6", 8", 10", 12", 13", 15", 16", 19", 200mm, 250mm, 315mm, 400mm, 500mm other custom wheel sizes available upon request

Brake Type: MST, AST, IST
with external spring: suffix: (E)

Brake Torque: Max brake torque is expressed as lb-ft for imperial size brakes and Nm for metric size brakes

Pushrod Type: Manual Adjust (MA) or Automatic Adjust (AA) pushrod

Thruster Size, sizes applicable to

200S brake types: ED23/5, ED30/5, ED50/6, ED50/12, ED80/6, ED80/12, ED121/6
ED121/12, ED201/6, ED201/12
with time delay: suffix: set (S), release (H), both (SH)

Thruster Voltage: 3 phase / 60 Hz Standard Voltages: 208, 230, 460, 575
3 phase / 50 Hz Standard Voltages: 230, 290, 400, 500, 690

Ambient Temperature

Package: (T1): -13°F to 122°F / -25°C to 50°C
(T2): 41°F to 158°F / 5°C to 70°C
(T3): 14°F to 158°F / -10°C to 70°C
(T4): -31°F to 122°F / -35°C to 50°C

Optional Features: Configurable Hand Release (HR) mechanism for manual release of brake

Optional Features: Limit Switch: Single limit switch - brake set or brake release (M1/2)
Single limit switch - hand release action (M3)
Two limit switches - brake set and brake release (M12)
Two limit switches - brake set or brake release and hand release action (M13/23)
Three limit switches - brake set, brake release, and hand release action (M123)

Optional Features: Stainless Steel (SS) hardware for increased resistance to corrosion and wear

Special Features: (SP) indicates extra feature(s) not considered above

Model number examples:

- 8MST-0230-MA-ED23/5-460-T1
- 10MST-0510-MA-ED30/5-460-T1
- 8MSTE-0240-AA-ED23/5S-575-T4-HR-M123-SS
- 10MSTE-0530-AA-ED30/5H-208-T2-HR-M12-SS

Other details:

Limit switch codes in the model number are described as indicating: brake set (M1), brake release (M2), and hand release action (M3). An M1 limit switch can be rearranged on the mounting bracket to be an M2 limit switch, and vice versa. The same limit switch and trigger are assembled onto the brake when either a single M1 or M2 switch is ordered. For this reason, the code (M1/2) is used in the model number, while M1 and M2 codes are not used in the model number.

When ordering brakes, please specify:

1. Desired torque for the brake to be factory set
2. Right side or left side of brake for nameplate to be installed at the factory
 - If fitted, the torque scale indicator of the external spring will face the same side as the nameplate
3. Zone R1, R2, L1, or L2 for hand release to be installed at the factory, if applicable
4. Latching configuration or non-latching configuration of hand release, if applicable
5. Factory default method is to place nameplate and torque scale indicator on right side of brake, and to place hand release in zone R1, if alternate placement is not specified.

MST Brake Specifications

0894AE/ACT	DIMENSIONS																			MST TORQUE						MSTE CONTINUOUSLY ADJUSTABLE TORQUE			
	E	F	G	H	J	K	L	M	N	P	Q	R	S	T	U	V	W	OX	BOLT	Y	ZF	ZG	A-C	B-C	A-D	B-D	A-C	A-D	A-D
57' ED32	4.75	4.00	1.50	5.06	17.06	16.50	21.56	14.01	15.37	12.45	2.06	3.15	4.38	5.31	-3.31	8.33	3.00	0.304	3/8	0.50	8.00	3.00	170	140	90	70	170-50	130-30	90-30
57' ED33	6.00	5.50	2.00	6.94	14.56	19.01	25.95	14.75	15.93	14.06	2.63	3.15	4.55	5.88	-3.50	10.84	4.00	0.404	3/8	0.50	11.00	4.00	230	200	130	100	240-60	130-30	100-30
58' ED30	7.00	6.00	2.50	8.25	16.06	20.49	28.68	16.94	18.09	14.28	3.25	3.15	4.43	6.23	-3.50	12.23	4.00	0.406	1/2	0.50	12.00	5.00	350	300	180	150	380-90	200-50	150-50
10' ED23	7.00	6.00	2.50	8.25	16.06	20.24	28.49	17.95	19.51	17.66	3.25	3.15	4.43	6.23	-3.50	12.23	4.00	0.406	1/2	0.50	12.00	5.00	350	300	180	150	380-90	200-50	150-50
10' ED24	7.00	6.00	3.00	9.56	18.44	22.85	32.41	21.12	16.40	18.00	3.63	3.15	4.69	7.38	-3.50	14.70	5.00	0.406	1/2	0.63	14.00	6.00	340	300	200	170	590-100	360-100	220-70
12' ED23	8.75	7.00	3.00	9.56	18.44	22.73	32.29	21.15	19.80	18.00	3.63	3.15	4.69	7.38	-3.50	14.70	5.00	0.406	1/2	0.63	14.00	6.00	340	300	200	170	590-100	360-100	220-70
12' ED24	8.75	7.00	3.00	9.56	19.06	24.59	34.16	21.51	22.66	20.54	3.63	3.84	6.69	7.38	-3.50	14.23	5.00	0.406	1/2	0.63	14.00	6.00	340	300	200	170	480-140	280-80	170-60
12' ED25	8.75	7.00	3.00	9.56	19.06	24.60	34.16	21.95	23.27	21.13	3.63	3.84	6.69	7.38	-3.50	14.23	5.00	0.406	1/2	0.63	14.00	6.00	340	300	200	170	480-140	280-80	170-60
13' ED23	8.75	7.00	3.00	10.06	18.94	23.35	33.29	21.51	16.35	14.64	3.63	3.15	6.69	7.38	-3.50	15.20	5.50	0.406	1/2	0.63	14.00	6.00	370	320	210	180	310-110	180-60	130-60
13' ED24	8.75	7.00	3.00	10.06	18.94	23.23	32.29	21.51	19.75	18.00	3.63	3.15	6.69	7.38	-3.50	15.20	5.50	0.406	1/2	0.63	14.00	6.00	370	320	210	180	310-110	180-60	130-60
13' ED25	8.75	7.00	3.00	10.06	19.56	25.09	35.16	21.51	22.66	20.54	3.63	3.84	6.69	7.38	-3.50	14.73	5.50	0.406	1/2	0.63	14.00	6.00	370	320	210	180	310-110	180-60	130-60
13' ED26	8.75	7.00	3.00	10.06	19.56	25.43	35.49	21.95	23.27	21.13	3.63	3.84	6.69	7.38	-3.50	14.73	5.50	0.406	1/2	0.63	14.00	6.00	370	320	210	180	310-110	180-60	130-60
15' ED20	10.50	9.00	3.50	11.88	22.75	28.14	40.02	25.69	24.63	22.55	4.38	3.84	8.45	9.06	-3.50	17.98	6.00	0.409	5/8	0.63	18.00	7.00	460	400	250	200	460-180	280-110	180-110
15' ED21	10.50	9.00	3.50	11.88	22.75	28.22	40.10	25.70	25.25	23.14	4.38	3.84	8.45	9.06	-3.50	17.99	6.00	0.409	5/8	0.63	18.00	7.00	460	400	250	200	460-180	280-110	180-110
15' ED22	10.50	9.00	3.50	11.88	24.50	29.71	41.59	30.76	31.91	29.77	4.38	4.72	8.45	9.06	-3.50	19.06	6.00	0.409	5/8	0.63	18.00	7.00	460	400	250	200	460-180	280-110	180-110
16' ED20	10.50	9.00	3.50	12.38	23.25	28.64	41.01	25.69	24.60	22.55	4.38	3.84	8.45	9.06	-3.50	18.48	6.50	0.409	5/8	0.63	18.00	7.00	460	400	250	200	460-180	280-110	180-110
16' ED21	10.50	9.00	3.50	12.38	23.25	28.72	41.10	25.70	25.21	23.14	4.38	3.84	8.45	9.06	-3.50	18.49	6.50	0.409	5/8	0.63	18.00	7.00	460	400	250	200	460-180	280-110	180-110
16' ED22	10.50	9.00	3.50	12.38	25.00	30.21	42.59	30.76	31.91	29.77	4.38	4.72	8.45	9.06	-3.50	19.56	6.50	0.409	5/8	0.63	18.00	7.00	460	400	250	200	460-180	280-110	180-110
19' ED20	13.25	9.25	5.00	14.63	26.38	31.53	46.16	33.32	26.70	24.73	6.38	3.84	10.63	9.44	-4.75	21.34	8.50	0.406	1	1.25	18.50	10.00	510	450	280	220	510-100	300-50	200-50
19' ED21	13.25	9.25	5.00	14.63	26.38	31.54	46.17	33.32	27.31	25.32	6.38	3.84	10.63	9.44	-4.75	21.34	8.50	0.406	1	1.25	18.50	10.00	510	450	280	220	510-100	300-50	200-50
19' ED22	13.25	9.25	5.00	14.63	28.06	33.17	47.80	34.54	31.35	29.28	6.38	4.72	10.63	9.44	-4.75	22.44	8.50	0.406	1	1.25	18.50	10.00	510	450	280	220	510-100	300-50	200-50
19' ED23	13.25	9.25	5.00	14.63	28.06	33.17	47.80	34.54	31.35	29.28	6.38	4.72	10.63	9.44	-4.75	22.44	8.50	0.406	1	1.25	18.50	10.00	510	450	280	220	510-100	300-50	200-50

* All dimensions are inches

* All Torques are lb-ft

* A, B, C, and D show connection points for thruster and pushrod to effect different brake torque

* Brake is shown with nameplate facing in right hand orientation

* M Maximum height of the brake, could be from any component, not necessarily from the component pictured

* N Height of the lever while the brake is released with thruster at maximum stroke

* P Height of the lever while the brake is set with thruster at typical thruster reserve stroke

* S, T Dimension S or T, whichever is greater, is the minimum clearance required to remove all pins as shown

* U Dimension is approximate, some brakes using the Automatic Adjust mechanism may require greater space at this location

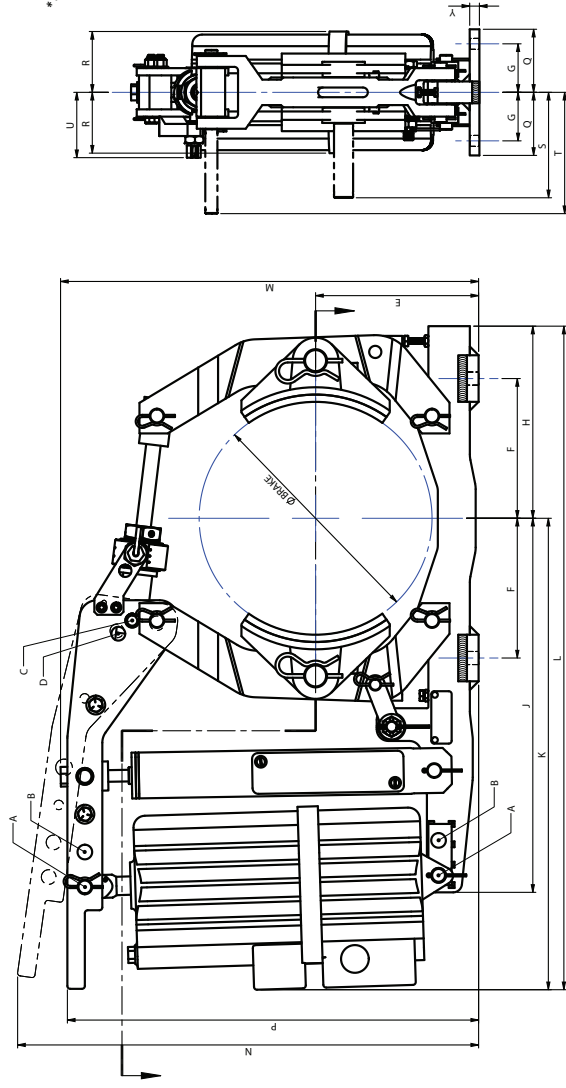

AST Brake Specifications

ØBRAKE/ACT	DIMENSIONS																										AST TORQUE						ASTE CONTINUOUSLY ADJUSTABLE TORQUE		AIST/AISE RECOMMENDED TORQUE	
	E	F	G	H	J	K	L	M	N	P	Q	R	S	T	U	V	W	ØX	BOLT	Y	ZF	ZG	A-C	B-C	A-D	B-D	A-C	A-D	AIST/AISE RECOMMENDED TORQUE	AIST/AISE RECOMMENDED TORQUE						
8"/ED23	7.00	3.25	2.88	6.94	14.56	19.01	25.95	15.75	16.93	15.06	3.69	3.15	4.55	5.88	-3.50	10.84	3.00	Ø0.69	5/8	0.44	6.50	5.75	230	200	120	100	240-60	120-30	100	100						
8"/ED30	7.00	3.25	2.88	6.94	14.56	18.79	25.73	18.73	20.35	18.44	3.69	3.15	4.55	5.88	-3.50	10.94	3.00	Ø0.69	5/8	0.44	6.50	5.75	350	300	180	150	380-90	200-50	100	100						
10"/ED23	8.38	4.00	3.13	8.25	16.06	20.43	28.68	17.92	17.46	15.66	3.81	3.15	5.43	6.25	-3.50	12.23	3.50	Ø0.69	5/8	0.56	8.00	6.25	350	300	230	200	330-100	220-70	200	200						
10"/ED30	8.38	4.00	3.13	8.25	16.06	20.24	28.49	19.33	20.88	19.03	3.81	3.15	5.43	6.25	-3.50	12.36	3.50	Ø0.69	5/8	0.56	8.00	6.25	510	450	350	300	530-140	360-100	200	200						
13"/ED23	9.88	5.75	4.50	10.06	18.94	23.35	33.41	22.25	17.48	15.76	5.38	3.15	6.69	7.38	-3.50	15.20	5.50	Ø0.81	3/4	0.63	11.50	9.00	370	320	210	180	310-110	180-60	550	550						
13"/ED30	9.88	5.75	4.50	10.06	18.94	23.23	33.29	22.28	20.88	19.13	5.38	3.15	6.69	7.38	-3.50	15.36	5.50	Ø0.81	3/4	0.63	11.50	9.00	550	490	320	280	520-150	300-90	550	550						
13"/ED50	9.88	5.75	4.50	10.06	19.56	25.09	35.16	22.64	23.79	21.67	5.38	3.84	6.69	7.38	-3.50	14.73	5.50	Ø0.81	3/4	0.63	11.50	9.00	800	700	500	430	780-180	490-110	1000	1000						
16"/ED50	12.13	7.50	5.38	12.38	23.25	28.64	41.01	27.32	26.22	24.17	6.50	3.84	8.45	9.06	-3.50	18.48	6.50	Ø1.06	1	0.75	15.00	10.75	1300	1100	700	600	1700-420	900-220	2000	2000						
16"/ED80	12.13	7.50	5.38	12.38	23.25	28.72	41.10	27.33	26.83	24.76	6.50	3.84	8.45	9.06	-3.50	18.49	6.50	Ø1.06	1	0.75	15.00	10.75	1800	1100	1000	1000	2500-420	1300-220	3000	3000						
16"/ED121	12.13	7.50	5.38	12.38	25.00	30.21	42.59	32.39	33.54	31.40	6.50	4.72	8.45	9.06	-3.50	19.56	6.50	Ø1.06	1	0.75	15.00	10.75	2500	2200	1600	1400	2700-1400	1600-900	3000	3000						
16"/ED201	12.13	7.50	5.38	12.38	25.00	30.21	42.59	32.39	33.54	31.40	6.50	4.72	8.45	9.06	-3.50	19.56	6.50	Ø1.06	1	0.75	15.00	10.75	4000	3500	2400	2200	3300-1400	2000-900	4000	4000						
19"/ED50	13.25	9.25	6.50	14.63	26.38	31.53	46.16	33.32	26.70	24.73	7.88	3.84	10.63	9.44	-4.75	21.34	8.50	Ø1.06	1	1.25	18.50	13.00	2800	2500	1600	1400	2300-620	1300-340	2000	2000						
19"/ED80	13.25	9.25	6.50	14.63	26.38	31.54	46.17	33.32	27.31	25.32	7.88	3.84	10.63	9.44	-4.75	21.34	8.50	Ø1.06	1	1.25	18.50	13.00	2800	2500	1600	1400	3400-620	1900-340	2000	2000						
19"/ED121	13.25	9.25	6.50	14.63	28.06	33.17	47.80	34.54	31.35	29.28	7.88	4.72	10.63	9.44	-4.75	22.44	8.50	Ø1.06	1	1.25	18.50	13.00	3200	2900	2100	1900	3700-2000	2400-1300	2000	2000						
19"/ED201	13.25	9.25	6.50	14.63	28.06	33.17	47.80	34.54	31.35	29.28	7.88	4.72	10.63	9.44	-4.75	22.44	8.50	Ø1.06	1	1.25	18.50	13.00	5100	4600	3300	3000	4600-2000	3000-1300	2000	2000						

* All dimensions are in inches

* All Torques are lb-ft

* A, B, C, and D show connection points for thruster and pushrod to effect different brake torque

* Brake is shown with nameplate facing in right hand orientation

*M Maximum height of the brake, could be from any component, not necessarily from the component pictured

*N Height of the lever while the brake is released with thruster at maximum stroke

*P Height of the lever while the brake is set with thruster at typical thruster reserve stroke

*S, T Dimension S or T, whichever is greater, is the minimum clearance required to remove all pins as shown

*U Dimension is approximate, some brakes using the Automatic Adjust mechanism may require greater space at this location

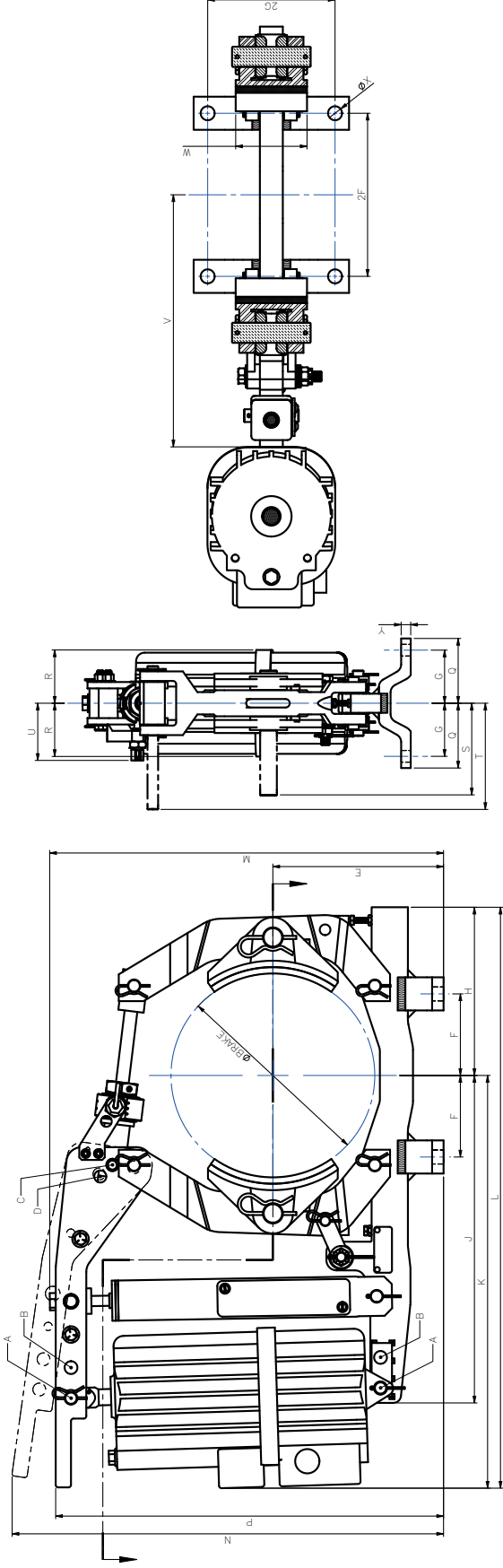

IST Brake Specifications

ØBRAKE/ACT	DIMENSIONS																				IST TORQUE				ISTE CONTINUOUSLY ADJUSTABLE TORQUE			
	E	F	G	H	J	K	L	M	N	P	Q	R	S	T	U	V	W	ØX	Y	BOLT	ZF	2G	A-C	B-C	A-D	B-D	A-C	A-D
200mm/ED23	155	145	27.5	176	370	481	657	377	407	360	43	80	116	150	~87	274	70	φ14	15	M12	290	55	310	270	160	140	320-80	160-40
200mm/ED30	155	145	27.5	176	370	476	652	453	494	446	43	80	116	150	~87	276	70	φ14	15	M12	290	55	470	400	240	200	510-120	260-60
250mm/ED23	185	180	32.5	210	408	517	727	427	416	370	54	80	138	159	~86	309	90	φ18	20	M16	360	65	470	410	310	270	440-140	290-90
250mm/ED30	185	180	32.5	210	408	512	722	463	503	456	54	80	138	159	~86	312	90	φ18	20	M16	360	65	690	600	470	410	710-190	480-130
315mm/ED23	225	220	40	256	481	586	842	538	418	375	63.5	80	170	187	~88	379	110	φ18	19	M16	440	80	480	420	270	240	410-150	230-80
315mm/ED30	225	220	40	256	481	583	839	539	505	460	63.5	80	170	187	~88	383	110	φ18	19	M16	440	80	720	640	410	360	670-200	380-120
315mm/ED50	225	220	40	256	497	630	886	549	579	525	63.5	97.5	170	187	~88	371	110	φ18	19	M16	440	80	1000	900	640	560	1000-230	630-150
315mm/ED80	225	220	40	256	497	639	886	561	594	539	63.5	97.5	170	187	~88	371	110	φ18	19	M16	440	80	1700	1500	1000	900	1700-230	1000-150
400mm/ED50	270	270	50	314	591	725	1039	656	628	576	76	97.5	215	230	~89	466	140	φ22	19	M20	540	100	1700	1500	900	780	2200-550	1200-290
400mm/ED80	270	270	50	314	591	727	1041	656	644	591	76	97.5	215	230	~89	468	140	φ22	19	M20	540	100	2800	2500	1500	1300	3300-560	1700-290
400mm/ED121	270	270	50	314	635	765	1079	785	814	760	76	120	215	230	~89	498	140	φ22	19	M20	540	100	3400	3000	2100	1800	3600-1900	2200-1100
400mm/ED201	270	270	50	314	635	765	1079	785	814	760	76	120	215	230	~89	498	140	φ22	19	M20	540	100	5300	4700	3300	2900	4300-1900	2700-1100
500mm/ED50	330	325	65	371	670	809	1180	840	671	622	92	97.5	270	240	~121	550	180	φ22	25	M20	650	130	4000	2200	1300	1200	3200-900	1800-470
500mm/ED80	330	325	65	371	670	809	1180	840	687	637	92	97.5	270	240	~121	550	180	φ22	25	M20	650	130	4000	3500	2200	1900	4800-900	2600-470
500mm/ED121	330	325	65	371	713	847	1218	871	845	737	92	120	270	240	~121	578	180	φ22	25	M20	650	130	4500	4100	2900	2600	5200-2800	3400-1800
500mm/ED201	330	325	65	371	713	847	1218	871	845	737	92	120	270	240	~121	578	180	φ22	25	M20	650	130	7200	6400	4600	4200	6500-2800	4200-1800

* all dimensions are millimeters

* All Torques are Nm

* A, B, C, and D show connection points for thruster and pushrod to effect different brake torque

* Brake is shown with nameplate facing in right hand orientation

*M Maximum height of the brake, could be from any component, not necessarily from the component pictured

*N Height of the lever while the brake is released with thruster at maximum stroke

*P Height of the lever while the brake is set with typical thruster reserve stroke

*S, T Dimension S or T, whichever is greater, is the minimum clearance required to remove all pins as shown

*U Dimension is approximate, some brakes using the Automatic-Adjust mechanism may require greater space at this location

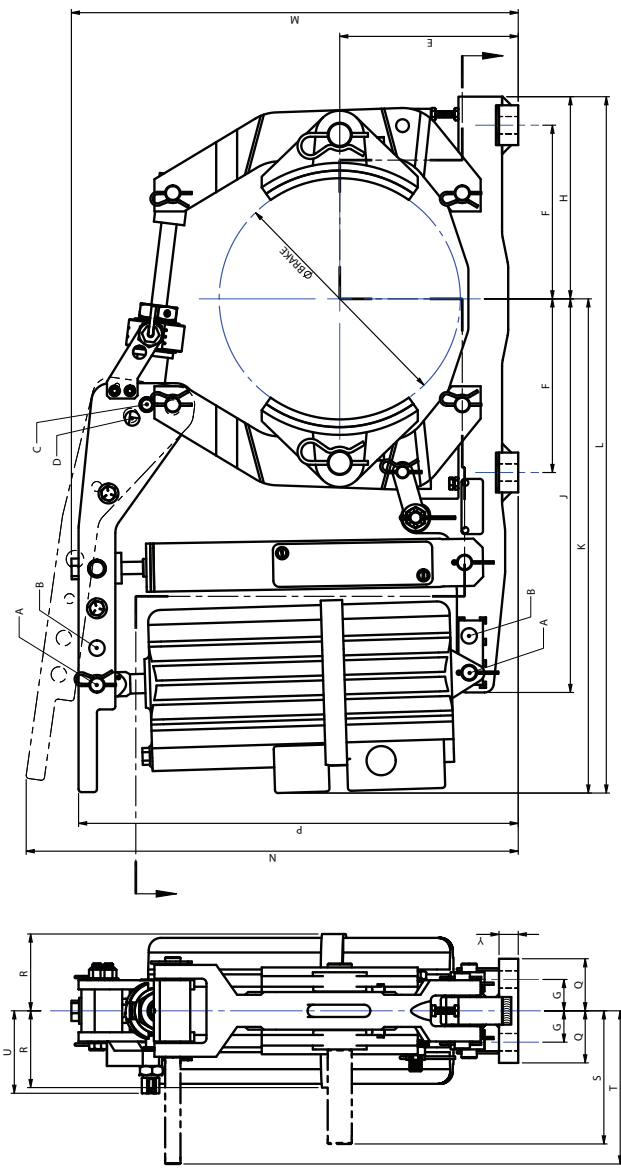



MAGNETEK
MATERIAL HANDLING

200S Brakes Technical Specifications
April 2019