

ELECTROMECHANICAL

Linear Actuators



Installation, Operation &
Maintenance Instructions

XT Series

450 - 1250 lbs Capacity

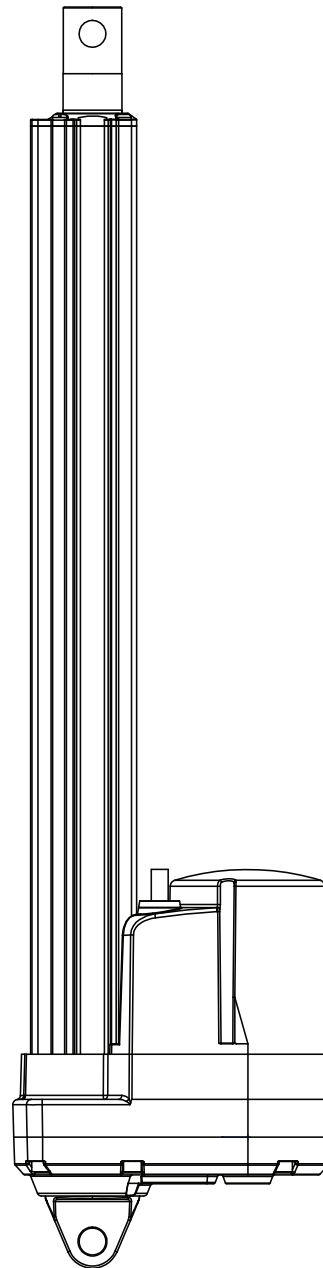

Publication Part No. SK-2391



CAUTION

This manual contains important information for the correct installation, operation and maintenance of the equipment described herein. All persons involved in such installation, operation, and maintenance should be thoroughly familiar with the contents. To safeguard against the possibility of personal injury or property damage, follow the recommendations and instructions of this manual and keep it for further reference.

WARNING

The equipment shown in this manual is intended for industrial use only and should not be used to lift, support, or otherwise transport people.

Contents

Section I General Information

	1-1.	General	3
	1-2.	Applications	3
	1-3.	Specifications	3
Table	1-1.	Specifications for XT Series Linear Actuators	3
	1-4.	Important Precautions	3
	1-5.	Operation	4
	1-6.	Equipment Power Off	4
	1-8.	Temperature	4
	1-9.	Warranty and Warranty Repair	4

Section II Installation

	2-1.	Mechanical Installation	4
Figure	2-1-1.	Use Mounting Pins of Correct Dimensions	4
Figure	2-1-2.	Off Center or Side Loads May Cause Bending	5
Figure	2-1-3.	Mounting Pins Must be Parallel to Each Other	5
	2-2.	Manual Drive Operation	5
Figure	2-1-1.	Torque Required Within 1.7 Nm	5
	2-3.	Electrical Installation	5
	2-4.	Cable	6
Figure	2-4-1.	Cable Without Signal	6
Figure	2-4-2.	Cable With Signal	6
	2-5.	Inrush Current	6
	2-6.	Wiring Definition	6
Table	2-6-1.	Two Limit Switches to Cut The Current	6
Figure	2-6-1.	Two Limit Switches	6
Table	2-6-2.	Two Limit Switches and POT	6
Figure	2-6-2.	Two Limit Switches and POT	6

Section III Product Specifications

	3-1.	Dimensional Drawing	7
Figure	3-1-1.	XT Series Linear Actuator Dimensional Drawing	7

Section IV Trouble Shooting

	4-1.	Troubleshooting	7
Table	4-1-1.	Symptoms, Possible Cause and Recommended Actions	7

Glossary

Vm+:	The positive pole of power input.	N.C.:	It is the pin of the limit switch which is normally short circuit and changed to open when the switch is triggered.
Vm-:	The negative pole of power input.	N.O.:	It is the pin of limit switch which is normally open and changed to short circuit when the switch is triggered.
RPM:	Number of turns per minute.	C.:	It is the common pin of limit switch when the circuit is either open or short.
AWG:	American wiring gauge.	Vp:	The reference voltage input to POT signal.
LS:	Limit switch installed inside the outer tube.	Vout:	The POT signal wire output value.
Up LS:	Upper limit switch is installed in fully extended end of stroke.		
Low LS:	Lower limit switch is installed in fully retracted end of stroke.		

Section I General Information

1-1. General

This manual provides instructions for the installation, operation and maintenance of the Duff-Norton XT Series linear actuator. It includes proper procedures for the disassembly, cleaning, inspection, rebuilding and assembly of the actuator. To ensure efficient, long, satisfactory use of this unit, these instructions should be followed closely.

1-2. Applications

The actuators described and illustrated in this manual are intended for industrial use only and should not be used to lift, support or otherwise transport people unless you have

a written statement from Duff-Norton which authorizes the specific actuator unit, as used in your application, as suitable for moving people.

1-3. Specifications

Every effort has been made to deliver this unit in its factory-approved state. You should, however, carefully inspect the actuator for damage that may have occurred during transit.

If you have questions or need additional help, please contact Duff-Norton at (800) 477-5002.

Table 1-1. Specifications for XT Series Linear Actuators

Part Number	Series	Voltage	Dynamic Rated Load	Available Stroke Length	Speed at Rated Load	Current Draw at Rated Load	Temp. Range	Re-straining Torque	Duty Cycle at Rated Load	Screw	Limit Switches
#	Prefix	VDC	lbs (N)	in (mm)	in/s (mm/s)	A	°F (°C)		%	Type	
XT450-2	XT	24	450 (2000)	5.9 (150)	.88 (22.3)	7.5	-13 to 150 (-25 to 65)	Keyed	25	ACME	Included
XT750-2		24	750 (3300)	11.8 (300) 17.7 (450)	.44 (11.1)	8.0	-13 to 150 (-25 to 65)	Keyed	25	ACME	Included
XT1250-2		24	1250 (5500)	23.6 (600)*	.24 (6.1)	6.8	-13 to 150 (-25 to 65)	Keyed	25	ACME	Included

*Stroke length on 600mm with POT is 570mm (22.4 in)

1-4. Important Precautions

In order to ensure that Duff-Norton actuators provide good service over a period of years, the following precautions should be taken:

1. Please read through this user manual before working on the equipment that the actuator will be a part of.
2. Adhere to the information contained in this user manual and on the product label. Never exceed the performance limits stated herein.
3. Be sure the actuator is not in operation.
4. Ensure the actuator is free from loads that could be released during mounting or dismounting
5. Refrain from unplugging any cables or connectors during operation or with power on.
6. Immediately stop using the actuator if it seems faulty or damaged. Notify Duff-Norton Customer Service so corrective actions can be taken.
7. Never disassemble the actuator as that will compromise the sealing and could impact the function of the actuator. Disassembly will void warranty.
8. Grease may be present on the extension tube. Contact with the grease is non hazardous. Please refrain from removing the film

CAUTION

Failure to follow the above listed Precautions may result in serious bodily harm, injury, or death.

1-5. Operation

1. Be sure the actuator is correctly mounted as indicated in the user instructions.
2. Be sure the equipment can be moved easily over the actuator's whole working area.
3. Be sure the actuator is connected to a main electricity supply/transformer with the correct voltage, specified on the actuator label.
4. Be sure that the connection bolts are secured safely and can withstand the wear.
5. Stop the actuator immediately if anything unusual is observed.
6. Ensure there is no side load present on the actuator
7. Only use the actuator within the specified working limits.
8. Refrain from having any contact with the actuator.

1-6. Equipment Power Off

1. Switch off the main supply to prevent any unintentional operation.
2. Regularly check for extraordinary wear

1-7. Duty Cycle

1. The standard duty cycle is 25%.
2. If the product is customized, please refer to the approval drawings

1-8. Temperature

1. The operating temperature range is -25°C to +65°C
2. The operational temperature range at full performance is +5°C to +45°C

1-9. Warranty and Warranty Repair

Subject to the conditions stated herein, Duff-Norton will repair or replace, without charge, any parts proven to Duff-Norton's satisfaction to have been defective in material or workmanship. Claims must be made within one year after date of shipment. Duff-Norton will not repair or replace any parts that become inoperative because of improper maintenance, eccentric loading, overloading, chemical or abrasive action, excessive heat, or other abuse.

Equipment and accessories not of Duff-Norton's manufacture are warranted only to the extent that they are warranted by the manufacturer, and only if the claimed defect arose during normal use, applications and service. Equipment which has been altered or modified by anyone

without Duff-Norton's authorization is not warranted by Duff-Norton. EXCEPT AS STATED HEREIN, DUFF-NORTON MAKES NO OTHER WARRANTIES, EXPRESS OR IMPLIED, INCLUDING WARRANTIES OF MERCHANTABILITY AND FITNESS FOR A PARTICULAR PURPOSE.

If you have any questions concerning warranty repair, please contact Duff-Norton Customer Service. Authorization for return must be received from the Duff-Norton before returning any equipment for inspection or warranty repair.

Section II Installation

2-1. Mechanical Installation

Use solid mounting pins with the proper dimension and support them at both ends.

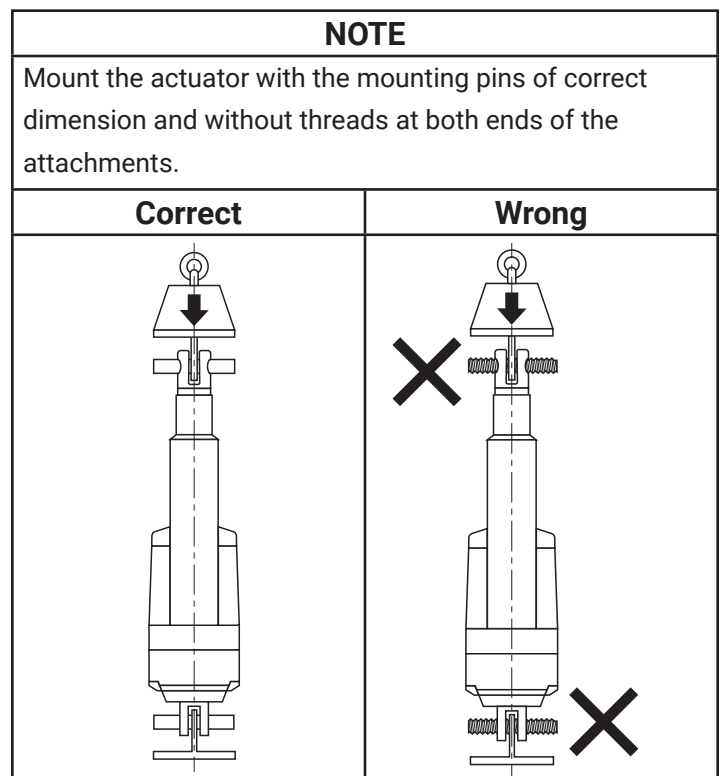
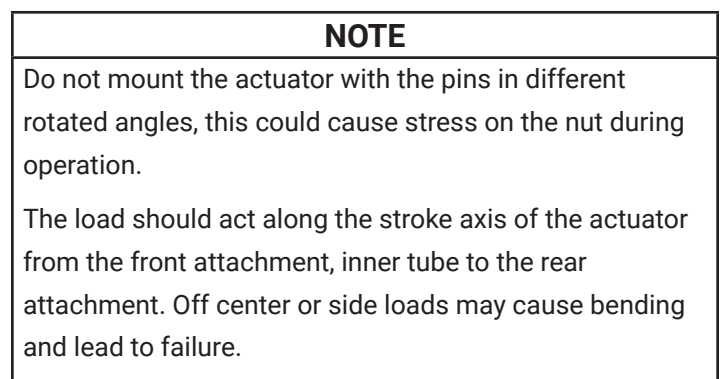

Figure 2-1-1. Use Mounting Pins of Correct Dimension.



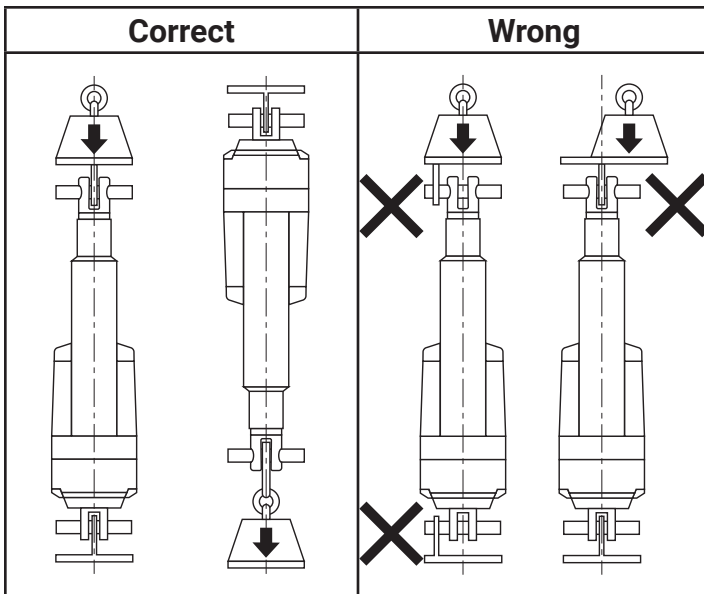

Figure 2-1-2. Off Center or Side Loads May Cause Bending

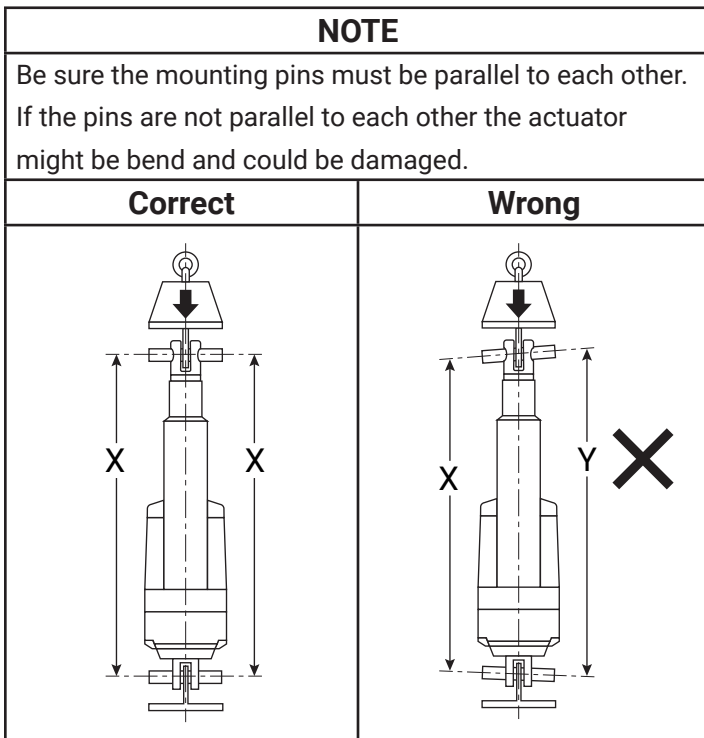

Figure 2-1-3. Mounting Pins Must Be Parallel To Each Other.

2-2. Manual Drive Operation

- 1 In case of a power failure a manual hand crank can be used.
- 2 Before performing, the power supply needs to be disconnected.
- 3 When mounting the actuator, ensure there is enough space between the rear adapter and any objects. This will allow the user override to be operated.

4. Use M8 Allen key for both the IP protection screw and the manual drive shaft inside

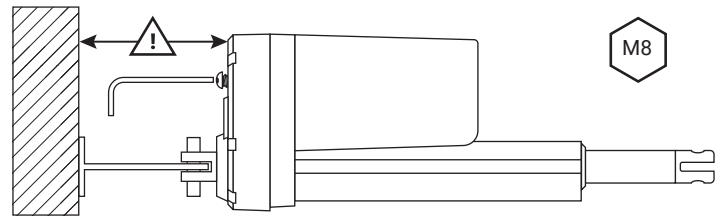

Figure 2-2-1. Manual Hand Crank

The torque required to manually move the extension tube is within 1.7 Nm, maximum 65 RPM.

Please do not run the outer tube to the end of stroke as that may damage the actuator.

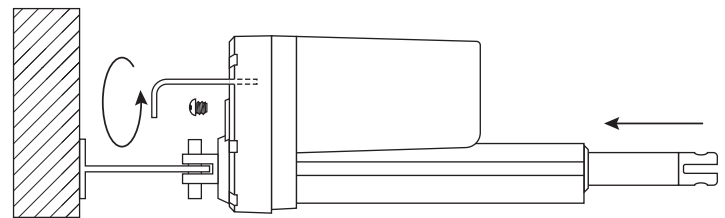

Figure 2-2-1. Torque Required Within 1.7Nm

2-3. Electrical Installation

1. Make sure the leads/cables leading to the motor are rated to handle the maximum current.
2. To reduce the chance of a crushing hazard, we recommend an emergency stop
3. If you are not using soft stop on a DC motor, a short peak of high voltage will be sent towards the power supply. When selecting the power supply , please ensure it is able to withstand the peak of high voltage.
4. To reduce the chance of interference, refrain from placing signal cables along power cables
5. Use a two wire system to prevent ground loop.
6. Please use shielded signal cables with applications that can be sensitive or if there is interference risk.
7. Please note, using long cables in combination with small lead cross sections and low voltages could lead to a malfunction due to voltage drop.
8. Use spark protection on relays and other coil operated devices
9. Please be sure the power to the actuator is off before working on the actuator and the wiring.

2-4. Cable

1. The actuator is supplied with a power cable (with/without signal wire). The standard cable for industrial applications has/have flying leads in the end for the user's equipment connections.

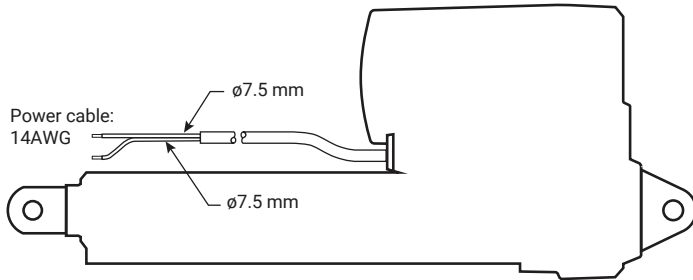

Figure 2-4-1. Cable Without Signal

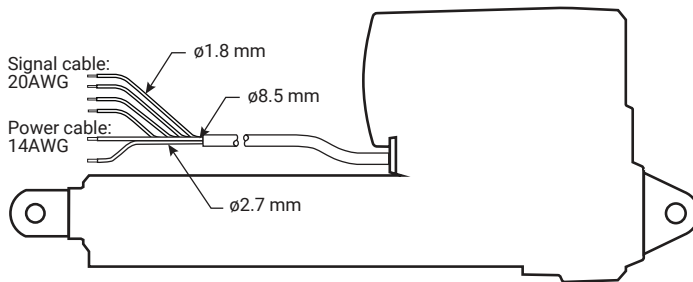

Figure 2-4-2. Cable With Signal

2-5. Inrush Current

1. When the actuator starts to work there is an inrush current to the motor that will be less than 0.2 seconds (up to four times the rated current)
2. Please select a power supply that is able to withstand the inrush current. Also, all contacts including switches and relay, should be selected with caution.

2-6. Wiring Definition

Table 2-6-1. Two Limit Switches To Cut The Current (Without Signal Output)

Wire	AWG	Description	Spec
Green	14	- Connect to Vm+ to extend the actuator - Connect to Vm- to retract the actuator	- 24V version: Input voltage 19~32V DC - 12V version: Input voltage 9~19V DC
Yellow	14	- Connect to Vm- to retract the actuator - Connect to Vm+ to extend the actuator	

The actuator is equipped with two limit switches to cut the current of the motor when the actuator moves to the end of each stroke and without any output signal.

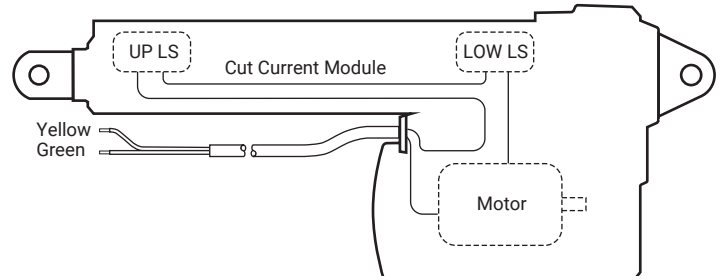
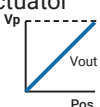

Figure 2-6-1. Two Limit Switches

Table 2-6-2. Two Limit Switches and POT

Wire	AWG	Description	Spec	
Green	14	- Connect to Vm+ to retract the actuator - Connect to Vm- to extend the actuator	- 24V version: Input voltage 19~32V DC - 12V version: Input voltage 9~19V DC	
Yellow	14	- Connect to Vm- to retract the actuator - Connect to Vm+ to extend the actuator		
White	20	POT signal ground	- POT output signal type is the voltage in proportion to the reference voltage input, which is relative to the position of the actuator  - The recommended power of the POT input is <2W - The brand and spec of the potentiometer embedded is Bourns, 0~10Kohm, 10 turns	
Red	20	POT signal output Vout		
		<table border="1"> <tr> <td>Fully Retracted</td> <td>Fully Extended</td> </tr> <tr> <td>0V</td> <td>Vp</td> </tr> </table>		Fully Retracted
Fully Retracted	Fully Extended			
0V	Vp			
Black	20	POT reference voltage input Vp, 5~32V DC (Recommended 10V)		

The actuator is equipped with two limit switches to cut the current of the motor when the actuator moves to the end of each stroke, and with POT position signal output.

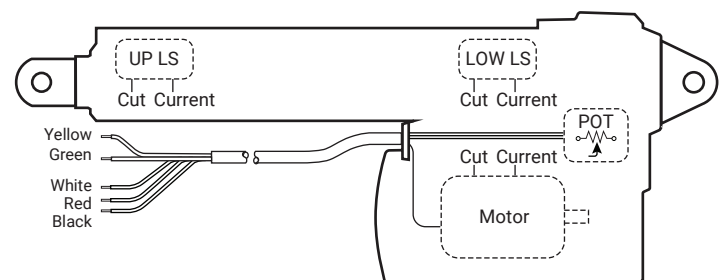

Figure 2-6-2. Two Limit Switches and POT

Section III Product Specifications

3-1. Dimensional Drawing

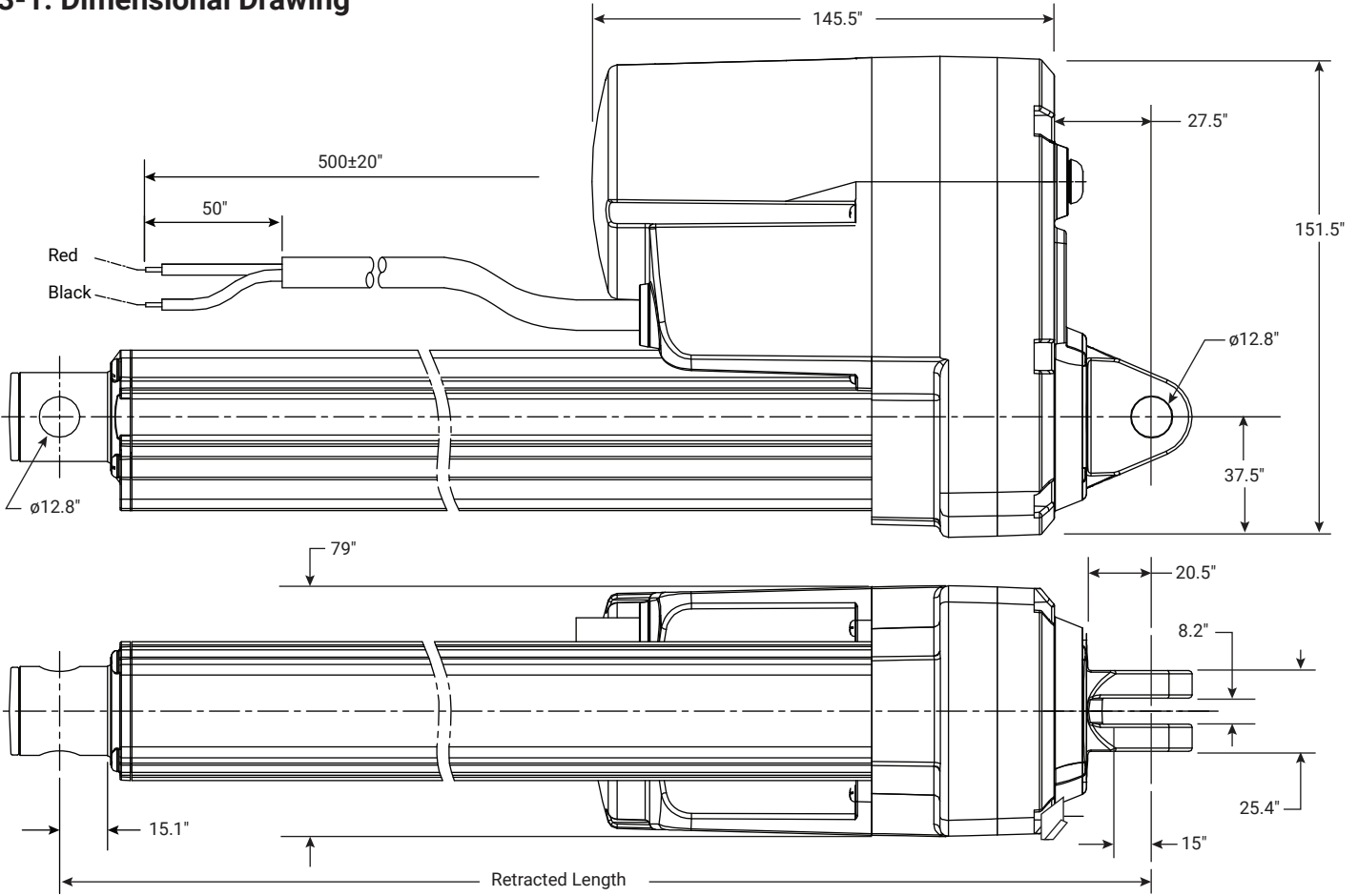

Figure 3-1-1. Dimensional Drawing

4-1. Troubleshooting

Section IV Troubleshooting

Table 4-1-1. Symptoms, Possible Cause and Recommended Actions

Symptom	Possible Cause	Action
Motor runs but spindle does not move	Gearing system or spindle damaged	Please contact Duff Norton Customer Service
No motor sound or movement	The actuator is not properly connected to the power supply	Check the connection to the power supply or the external control unit
	Customer fuse burned	Check the fuse
	Cable damaged	Please contact Duff Norton Customer Service
Excessive power consumption	Misalignment or overload in the application	Align or reduce the load. Try running the actuator without load
Actuator cannot lift full load or motor runs too slowly	Insufficient power supply	Check the power supply is properly plugged in
	Load is higher than specified	Reduce the load
No signal or incorrect feedback output	Cable damaged	Please contact Duff Norton Customer Service
	Wrongly connected	Check the wiring
	Signal is constantly high/low	Run the actuator to full extension & retraction Reconnect the cables and set parallel configuration again



2020 © Duff-Norton® - A Columbus McKinnon Company.
All rights reserved.
9415 Pioneer Avenue, Suite 100, Charlotte NC 28273
800-477-5002 • www.duffnorton.com • duffnorton@cmworks.com



SK-2391
12/15/20